



DFB LASER MODULE

OEM Solution for Fiber-Coupled High Power DFB Lasers

PRODUCT DATASHEET

The EM650 integrates a high-power fiber-coupled DFB laser with both an ultra-low noise laser current source and temperature controller. It represents a precision OEM solution for fiber-coupled high power DFB lasers operating with excellent frequency stability, narrow linewidth, low noise, and stable polarization.

The module contains a high-power DFB laser, optical isolator, single-mode fiber pigtail, thermo-electric cooler, thermistor, and monitor detector integrated with a laser current source, temperature controller, and monitor detector readout amplifier. The entire module operates from a single +5 V supply.

The unit provides a bi-directional power adjust input that may be used for SBS prevention, for constant power operation in conjunction with the monitor detector readout signal and an external control loop, or for finely adjusting the laser oscillation frequency via chirp. The unit also incorporates a bi-directional temperature adjust input for coarse tuning of the laser oscillation frequency.

The module is designed and built using EM4's high-reliability platform for defense components and incorporates an advanced ultra-low noise laser current source. It drives the internal TEC with a class AB linear H-bridge and incorporates multiple layers of EMI protection. It is EM4's highest performance integrated laser solution and offers performance comparable to laboratory equipment in a much smaller package.



Key Features

- Integrated current source
- Integrated temperature controller
- Integrated monitor detector amplifier
- High optical output power
- ITU wavelengths – Full C band coverage
- Low RIN
- Narrow linewidth
- PM/SM fiber with or without furcation tubing

Key Benefits

- Simple interface
- Small form factor
- Operates from single +5 V supply

Applications

- Long haul WDM transmission
- RF Links
- CATV
- Seeding
- Sensing
- Low-noise high-power source

EM650

Datasheet ref DS 7046 revision No. 6

As part of our policy of continuous product improvement, we reserve the right to change specifications at any time.

Absolute Maximum Ratings

Stresses beyond those listed under “Absolute Maximum Ratings” may cause permanent damage to the device. These are stress ratings only and operation of the device at these or conditions beyond these is not implied. Exposure to absolute maximum ratings for extended periods of time may affect device reliability.

| Parameter | Sym. | Condition | Min | Max | Unit |
|---|------------------|--|---------|----------------------|------|
| Storage temperature | T _{STG} | non-condensing atmosphere | -40 | +85 | °C |
| Operating temperature | T _{OP} | temp. at base of module, non-condensing atmosphere | -15 | 65 | °C |
| Voltage supply | V _{CC} | | 4.7 | 5.5 | V |
| Current supply | I _{CC} | | | 3.5 | A |
| Laser enable input voltage | LE | | GND-0.3 | V _{CC} +0.3 | V |
| Laser enable input current | I _{LE} | | | 2 | mA |
| Power adjust input voltage | V _{pa} | Warning: see notes | 0 | 2.6 | V |
| Power adjust input current source or sink | | Warning: see notes | -3.5 | 3.5 | mA |
| Temperature adjust input voltage | V _{ta} | Warning: see notes | 0 | 5 | V |
| Temperature adjust input current source or sink | | Warning: see notes | -3.5 | 3.5 | mA |
| Monitor detector output voltage | V _{MON} | | | V _{CC} | V |
| Monitor detector output current source or sink | I _{MON} | | -15 | 15 | mA |
| Optical output power | Pop | | | 110 | mW |

Optical Characteristics

T_{OP}=25°C unless otherwise noted. All parameters measured after an initial 60s settling time. V_{CC}= LE = 5.0V with PA and TA open.

| Parameter | Sym. | Condition | Min | Typ | Max | Unit |
|---|------------------|---|-----|------|------|--------|
| Optical output power setpoint | P _{OP} | See ordering information | Pop | | | mW |
| Optical output power fluctuation ¹ | ΔP _{OP} | 1σ, t _m =400s, 0.1s avg&period | | 20 | 50 | PPM |
| Long-term power fluctuation | ΔP _{OP} | 1σ, t _m =20hr, 0.1s avg, 18s period | | 200 | 500 | PPM |
| Temperature dependent power drift | ΔP _T | -10 ≤ T _{OP} ≤ 60° | | | 500 | PPM/°C |
| Optical frequency accuracy ² | F _{OP} | | -5 | | +5 | GHz |
| Optical frequency stability ³ | ΔF _{OP} | See note 3 | | <20 | | MHz |
| Temperature dependent frequency drift | ΔF _T | -10 ≤ T _{OP} ≤ 60° | | | ±200 | MHz/°C |
| Side mode suppression ratio | SMSR | | 30 | | | dB |
| Polarization extinction ratio | | w/ PM fiber only | 17 | 20 | | dB |
| Optical isolation | | | 30 | 35 | | dB |
| Linewidth | Δν | | | 170 | 500 | kHz |
| Relative intensity noise | RIN | 50 MHz to 18GHz | | -155 | -150 | dBc/Hz |
| Cold start settling time | | V _{CC} =V _{EN} 0→5V | | | 30 | s |
| Rise time (hot start) | t _R | V _{EN} =0→5V | | 30 | | ms |
| Fall time (hot standby) | t _F | V _{EN} =5→0V | | 5 | | μs |
| Back facet tracking over temp | | | -10 | | +10 | % |

Electrical Characteristics

| Parameter | Sym. | Condition | Min | Typ | Max | Unit |
|------------------------------|------------------|---------------------------|-----|-----|-----|------|
| Voltage supply | V _{CC} | across inputs | | 5 | | V |
| Current supply | I _{CC} | | | | 3 | A |
| Laser enable high | LE _H | | 3.5 | | | V |
| Laser enable low | LE _L | | | | 1.5 | V |
| Laser enable input impedance | Z _{LE} | | | 5 | | kΩ |
| Power adjust ⁴ | V _{pa} | Warning: see notes | 0 | | 2.2 | V |
| Power adjust input impedance | Z _{PA} | to 2V V _{ref} | | 1 | | kΩ |
| Power adjust bandwidth | | -3dB | | 8 | | kHz |
| Temperature adjust | V _{ta} | Warning: see notes | 1.5 | | 3.5 | V |
| Temp adjust input impedance | Z _{ta} | to 2.5V V _{ref} | | 1 | | kΩ |
| Monitor detector output | V _{MON} | at Pop | 1 | | 3 | V |

Environmental Characteristics

| Parameter | Sym. | Condition | Min | Typ | Max | Unit |
|-------------------------|------------------|--|-----|-----|-----|------|
| Storage temperature | T _{stg} | non-condensing | -40 | | +85 | °C |
| Operational temperature | T _{op} | temp. at base of module, non-condensing | -10 | | +60 | °C |

Electrical Connector

| Pin | Name | Description |
|------------------|------------------|--|
| 1 | V _{CC} | Voltage supply |
| 2 | V _{CC} | Voltage supply |
| 3 | GND | Ground connection |
| 4 | GND | Ground connection |
| 5 | GND | Ground connection |
| 6 | TA | Temperature Adjust Input |
| 7 | V _{mon} | Monitor Voltage Output |
| 8 | LE | Laser Enable |
| 9 | PA | Power Adjust Input |
| Shield | | Connected to connector shield only |
| Mating connector | | DB-09F, Standard DB-09 Female/Receptacle/Socket Connector |

Basic operating circuit

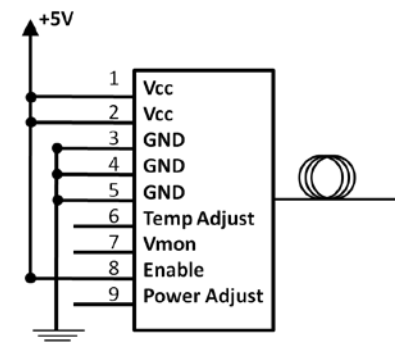

Optical Fiber Specification

| Parameter | Type | Unit |
|---------------------|---|------|
| Fiber type | Single-mode PM or non-PM | - |
| Core diameter | 8 | μm |
| Outer diameter | 125 | μm |
| Buffer diameter | 250 (optional 900 μm loose buffer avail.) | μm |
| Buffer material | Acrylate (optional loose-buffer is PVDF) | - |
| Minimum length | 1 | m |
| Minimum bend radius | 35 | mm |
| Connector type | FC or SC/APC, key parallel to slow axis; key type is tight-fit/narrow | - |
| Output polarization | Parallel to slow axis | - |

Mechanical drawing

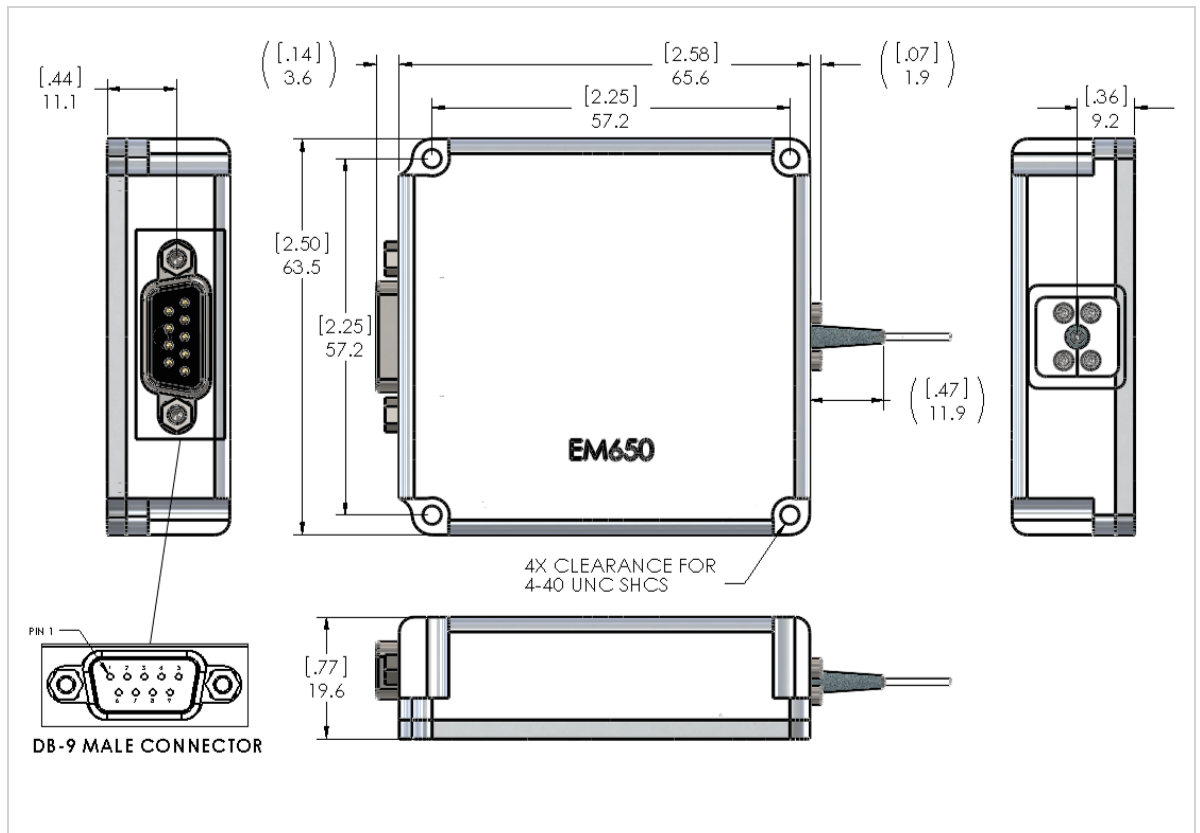

Typical Operating Characteristics (80 mW Module)

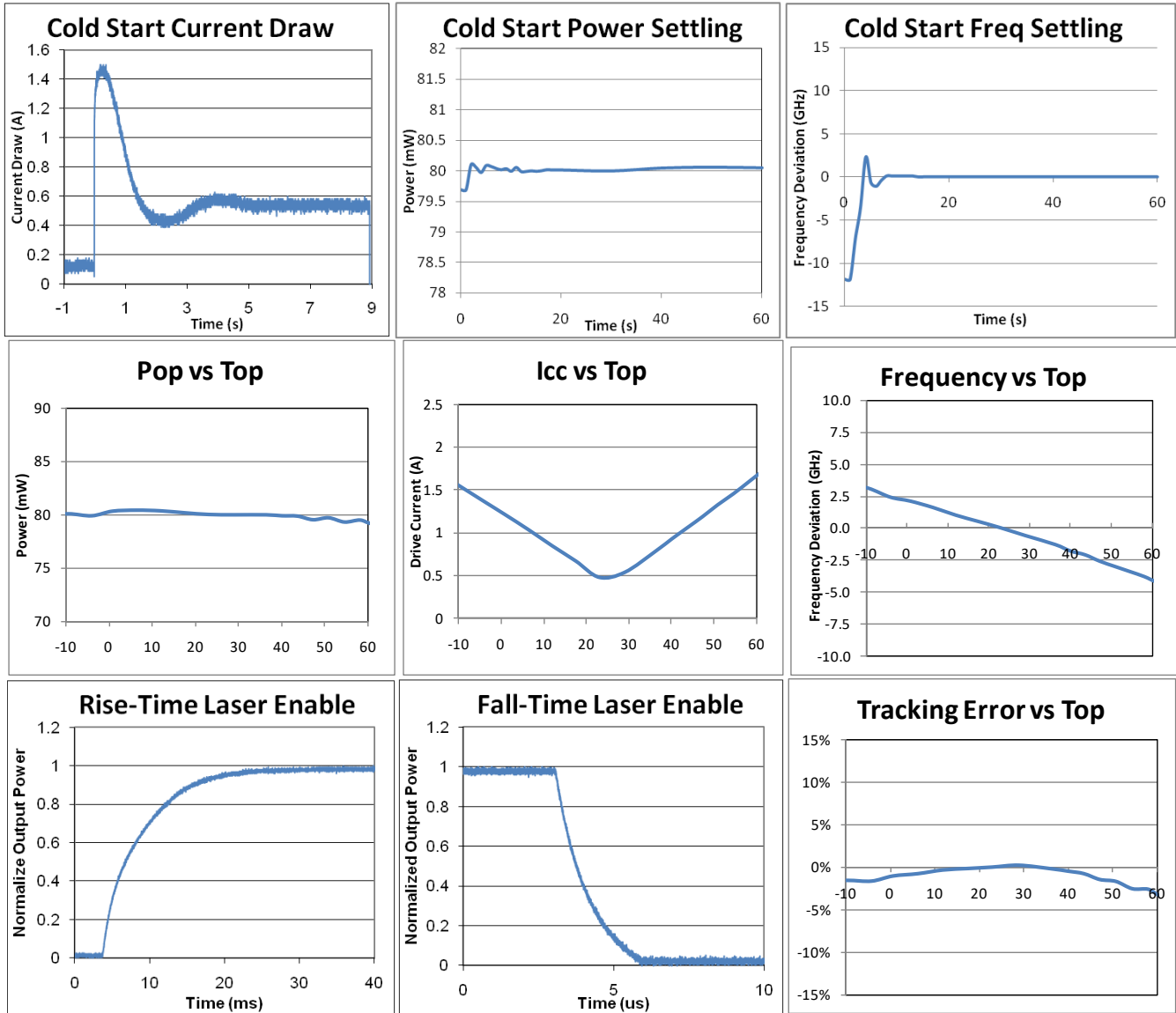

Typical Operating Characteristics (continued)

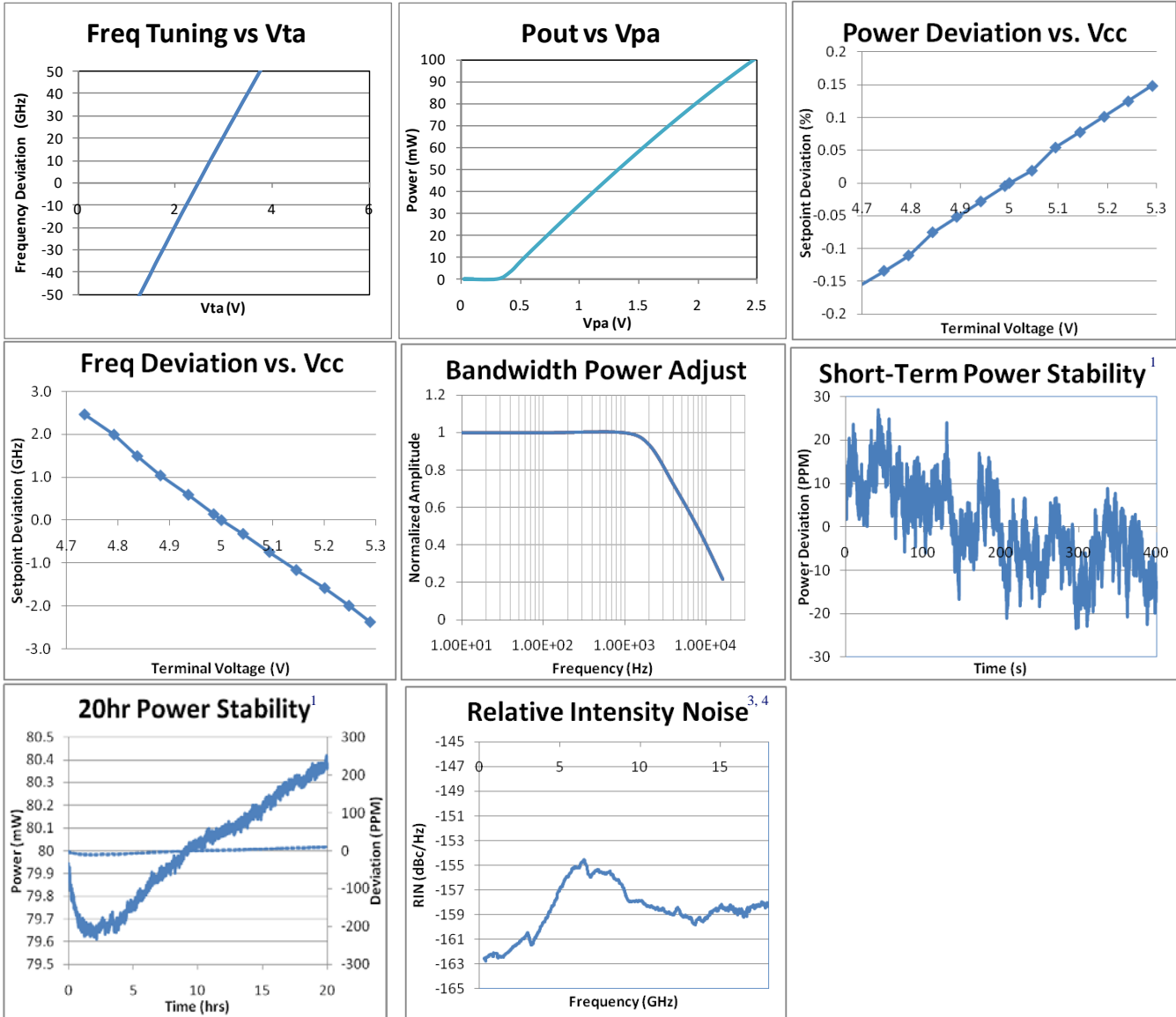

- 1 Power stability of this magnitude is strongly influenced by any movement of the fiber. To duplicate this stability measurement the fiber must be secured and motionless.
- 2 For 228.849 THz (1310 nm) lasers the laser frequency tolerance is ± 1.750 THz (± 10 nm).
- 3 Frequency stability measured by heterodyne of two free running EM650 units over 100s.
- 4 The peak of the RIN curve corresponds to the relaxation oscillation frequency of the laser which varies in proportion to the drive current above threshold by $f_{\text{relax}} \propto ((I_d/I_{\text{threshold}}) - 1)^{1/2}$. Customers employing this device in RIN sensitive applications should therefore be aware that reducing power using the PA input will reduce performance.

Application Notes

WARNINGS: several of the parameters listed in the specifications above are denoted with a warning. These warnings are covered by the following notes which should be understood before operating the device.

Mounting

The EM650 is conductively cooled through its base and needs to be mounted using a thermal interface material to a customer supplied heatsink. EM4 recommends Panasonic PGS series pyrolytic graphite sheets, available in the US from Digi-Key Corporation. Care should be taken to keep the base temperature of the module between -10 and 60°C at all times during operation.

Noise suppression

The EM650 is a no-compromises low-noise integrated laser solution; the temperature controller output is class AB linear, there are no DC/DC converters in the module, the lowest noise components and architectures available are used along with heavy filtering and EMI shielding. Nevertheless, power supply ripple and noise should be minimized, and the cable shield should be connected to the EM650 connector shield and tied to the appropriate signal at the power supply end of the cable.

Power Adjust (PA)

The EM650 is designed to run in constant current mode with the drive current set for the as-ordered output power to achieve the highest possible performance. However, some applications require fine tuning of the laser bias current. The PA input provides this functionality, but its use carries an amount of risk. If bias adjustment is not required, this input should be left open. Use of this input carries the potential to overdrive the laser and/or circuitry with the ability to destroy or drastically reduce the device lifetime. No internal protections on this input are provided, but the user is encouraged to clamp or otherwise limit the voltage and current that may be applied to this input. The default operating power corresponds to an input of 2.05 V. For maximum reliability it is recommended that power only be reduced, although if required it can be driven as high as 2.2 V (corresponding to a 10% boost in output power). The safest method of using this input is to pull the voltage down using an external resistor or potentiometer to ground. Applying a resistance

to ground will create a voltage divide circuit between the external resistance and an internal resistance of 1 K to the 2.05 V reference.

Damage due to overdrive will not be covered under warranty. Use of this input will likely decrease the performance of the EM650 by bypassing its internal ultra-low noise voltage reference.

The PA input must never be shorted directly to Vcc which would cause circuit malfunction or rapidly destroy the DFB laser.

Temperature Adjust (TA)

The EM650 is designed to operate the laser chip at a constant temperature holding the output frequency within 5 GHz of the ordered frequency.

However, some applications require coarse tuning of the output frequency via temperature. In these cases, the laser may be tuned using the TA input. Temperature deviations of more than a few degrees (50 GHz in laser frequency) from the as-ordered setpoint may result in decreased stability and increases the likelihood of the laser experiencing a longitudinal mode-hop. The achievable tuning range will depend on the specific laser chip, the ambient temperature, and the thermal resistance to the ambient.

Use of this input carries the inherent potential of overdriving the TEC. The TA input is clamped to Vcc through integrated protection diodes. If Vta is established before Vcc these clamp diodes will conduct. The input current should always be limited to ≤ 3.5 mA to prevent destruction of the clamp diodes. The safest method of driving this input is with a tri-state output whose output is current limited when active, maintained at high-impedance until Vcc is established, and whose output returns to high-impedance before Vcc is removed.

The device warranty will not be honored for lasers with overdriven TECs. Use of this input also carries the likelihood of decreased frequency stability as it bypasses the internal ultra-low noise voltage reference.

The TA input must never be shorted directly to Vcc or ground which would cause circuit malfunction or rapidly destroy the DFB laser.

Grounding

Care must be taken with grounding, cabling, and connections due to the amount of current the module consumes. Make sure that the voltage on pins PA/TA reference ground as close to the EM650 as possible if either input is connected.

DO NOT connect the cable shield to ground at both ends of the cable to avoid producing a ground loop. **DO NOT** connect the EM650 housing to ground to avoid producing a ground loop.

Startup Considerations

The EM650 consumes a considerable amount of current in the startup phase and when operating at temperature extremes. A voltage source plus cabling able to deliver the maximum specified current at no less than the minimum voltage is therefore needed. Current limiting below the specified maximum during the startup phase will result in an internally measured drive voltage lower than specified. This condition can result in permanent, non-warrantable damage to the device.

If the user fails to sequence the supplies as described in the Power and Temperature adjust sections of this document and Application Note DS-7047, the device will immediately suffer non-warrantable damage or destruction.

Applications Information

Be sure to check the EM4 website for the latest applications information for this device. Application Note DS-7047 covers general usage of the EM650 along with information particular to tuning via temperature or chirp. If you plan to tune this device, it is highly recommended that you read this Application Note. A series of short videos showing optical heterodyne measurements that illustrate laser line stability are also available on the website.

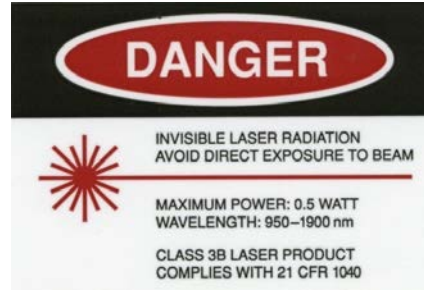

IMPORTANT:

Do not connect the DB-9 connector on the EM650 to any commercial laser controller.

WARNING: This device requires between 4.6 V and 5.5 V as measured from the Vcc to GND terminals. These voltages must be maintained for currents ranging from 0-3A necessitating the use of short wires and/or large AWG wire.

Failure to supply sufficient voltage at the device terminals may result in excess current draw and permanent, non-warrantable damage. If the device draws 3 A for more than 3 seconds, turn off power and check for excessive wiring resistance or a baseplate temperature outside the operational range.

WARNING: The TA and PA inputs should be driven with a current limited source with sequencing of the signal and power supply as described in the datasheet. Failure to follow these guidelines has the potential to cause non-warrantable damage to the drive electronics and/or laser module. If the device is to be tuned using either the PA or TA input, it is highly recommended that the user read and understand the EM4 application note “DS-7047 Frequency Tuning a DFB Laser,” available on the EM4 website.

WARNING: A thermal interface material is required between the EM650 and a customer supplied heatsink. EM4 recommends the use of Panasonic PGS Series flexible graphite sheets available in the US from Digi-Key Corporation.

Ordering information

The EM650 part number has the following structure: EM650-FFFFFF-POW-FIBUM-CON-NA

Valid values for each field are shown below.

| Code | | ① | ② | ③ | ④ | ⑤ | |
|------|-----------|--------------------------------------|---|----------------------------|--|--------------|---------------|
| E | M | | | | | | |
| ① | Model | 650 | | | 651 | | |
| | Code | 14-PIN DFB w/integrated electronics | | | 14-PIN DFB w/integrated electronics, no internal optical isolator | | |
| ② | Frequency | Frequency in GHz ¹ | | | | | |
| | Code | XXXXXX | | | | | |
| ③ | Power | Available at 1310 nm only (PM/SM) | 40 mW output | 50 mW output | 63 mW output | 80 mW output | 100 mW output |
| | Code | 10/15 ² | 40 | 50 | 63 | 80 | 100 |
| ④ | Fiber | Single-mode fiber, 250 um buffer | Single-mode fiber, 900 um loose buffer | PM fiber, 250 um buffer | PM fiber, 900 um loose buffer | | |
| | Code | SM250 | SM900 | PM250 | PM900 | | |
| ⑤ | Connector | FC/APC | | | SC/APC | | |
| | Code | FCA | | | SCA | | |

1 Standard frequencies range from 192.100 THz to 196.000 THz in increments of 100 GHz, with other frequencies available upon request. 1310 nm devices are 228.849 THz with a 1.75 THz tolerance.

2 1310 nm lasers with PM fiber outputs are only available in 10 mW versions.

For further information

EM4
T: +1 781-275-7501
E: sales@em4inc.com

EM4inc.com